

- USB_RST_PWREN_H >> PMIC_VDC
- GPIO1_D5_1V8_D >> PWR_KEY_L
- PWR_KEY_L >> PWRON_L
- PWRON_L >> PMIC_EXT_EN_OUT
- PMIC_EXT_EN_OUT >> SARADC_VIN2_LCD_ID1
- BATT_TC_L << GPIO3_D3_1V8_D
- GPIO3_D3_1V8_D << GPIO3_B1_3V3_U
- GPIO3_B1_3V3_U << I2C4_SDA_M3_3V3
- I2C4_SDA_M3_3V3 << I2C4_SCL_M3_3V3
- I2C4_SCL_M3_3V3 << BOOT_CONFIG
- BOOT_CONFIG << GPIO1_C0_1V8_U
- DC_DET << DC_DET

D C 没输入为高, 充电为低, 充满为高

辅助充电, 器睡时高, 灯 XSR 灯状态不对

COOL PI

YANYI www.cool-pi.com

Project: **COOLPI-NOTEBOOK**

File: **<Page name>**

Date: **Wednesday, January 10, 2024** Rev: **<Revision>**

Designed by: **<designer>** Reviewed by: **<Checker>** Sheet: **1 of 12**

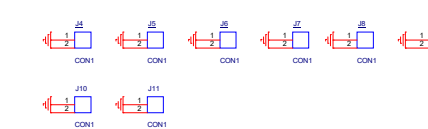
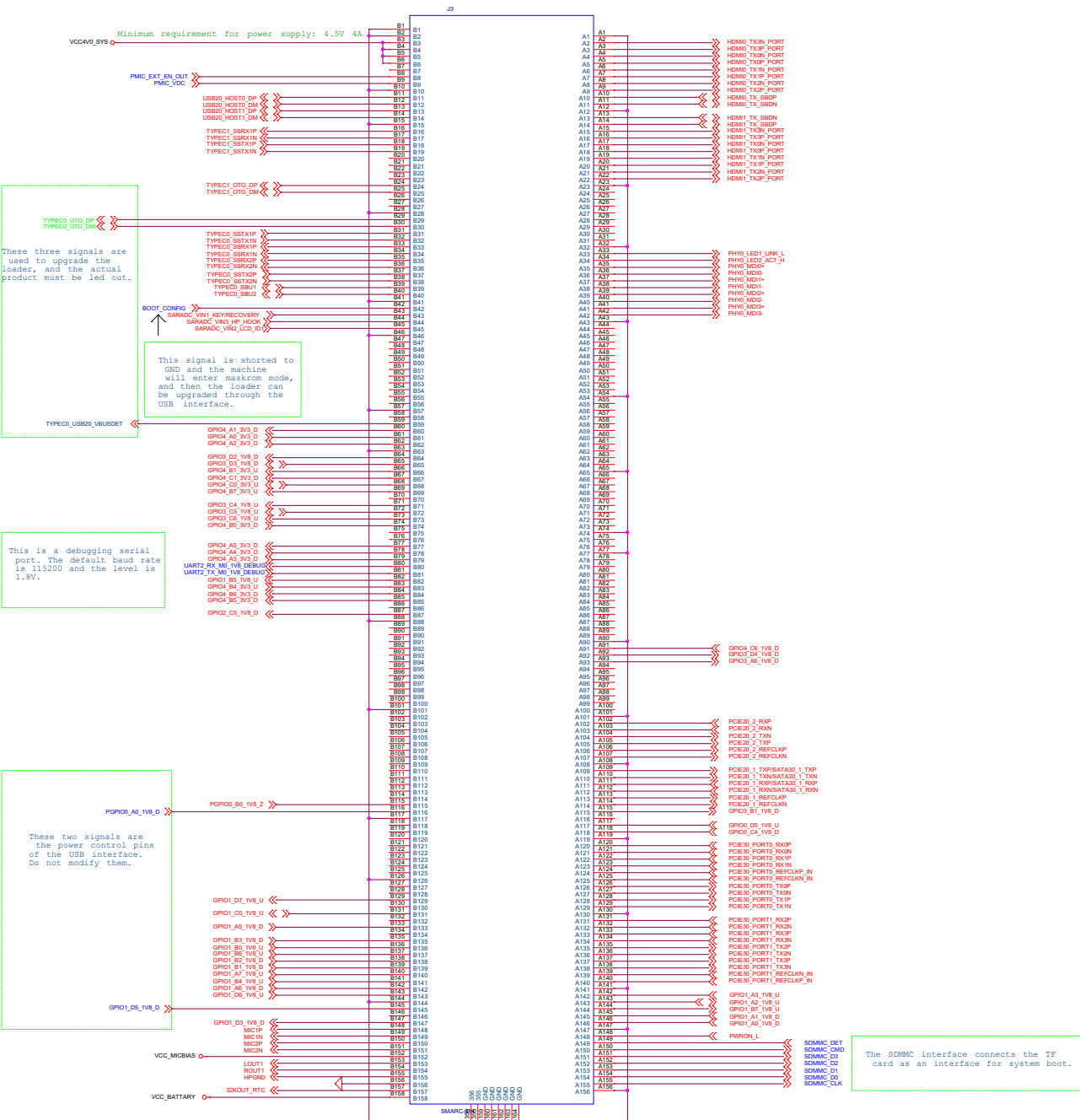

The SDMMC interface connects the TF card as an interface for system boot.

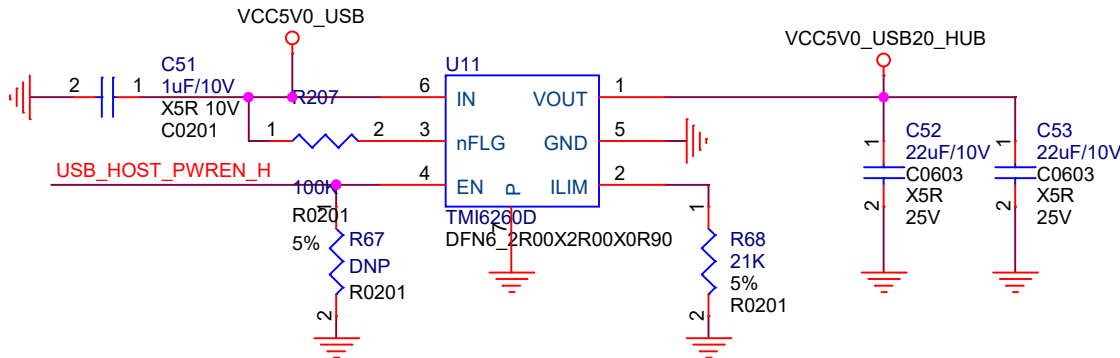
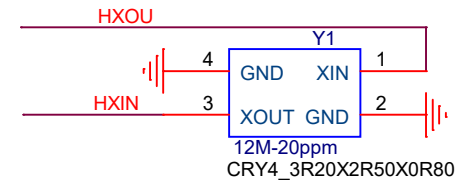
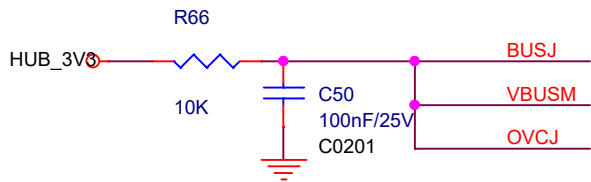
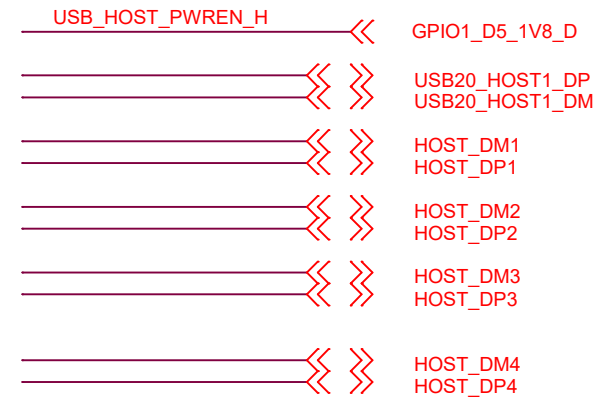
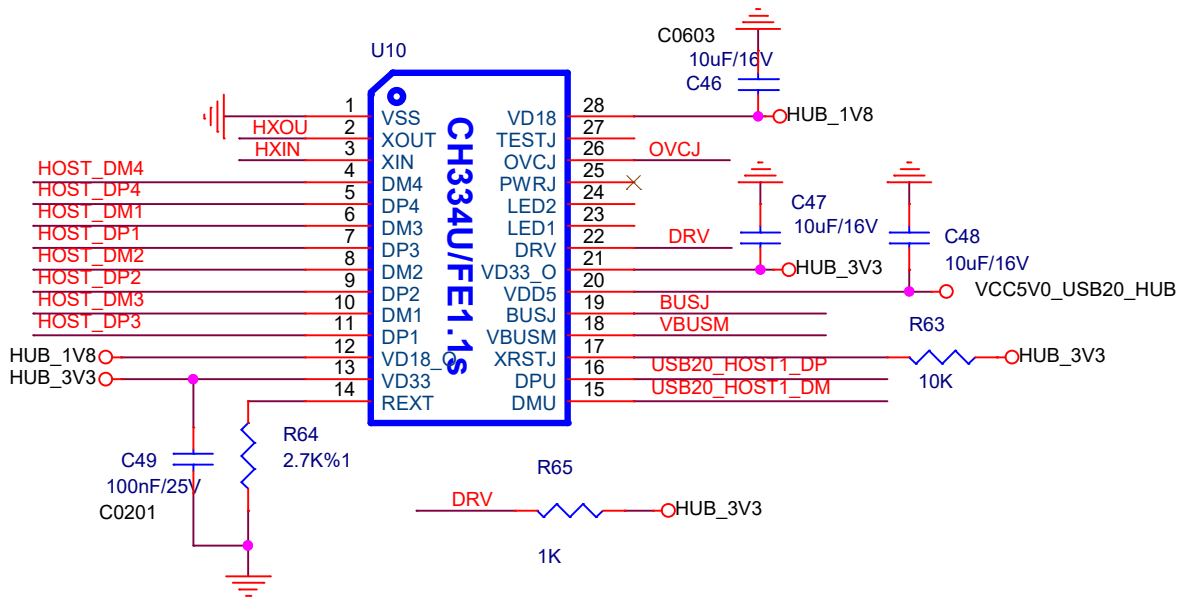

YANYI

www.cool-pi.com

Project:		COOLPI-NOTEBOOK	
File:		<Page name>	
Date:	Wednesday, January 10, 2024	Rev:	<Revision>
Designed by:	<designer>	Reviewed by:	<Checker>
Sheet:	3 of 12		

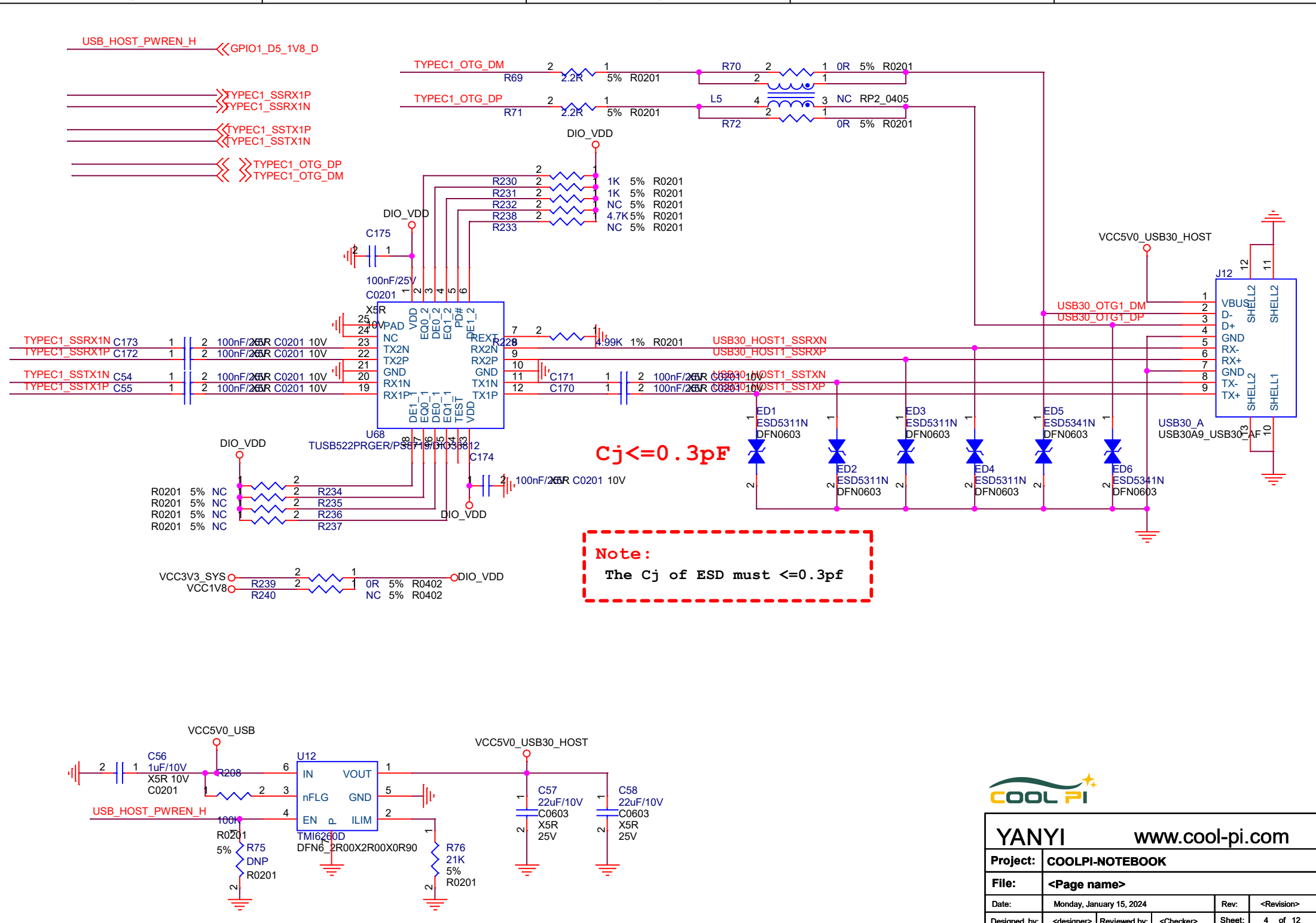

$C_j \leq 0.3\text{pF}$

Note:
The C_j of ESD must $\leq 0.3\text{pF}$



YANYI www.cool-pi.com

Project:	COOLPI-NOTEBOOK		
File:	<Page name>		
Date:	Monday, January 15, 2024	Rev:	<Revision>
Designed by:	<designer>	Reviewed by:	<Checker>
		Sheet:	4 of 12

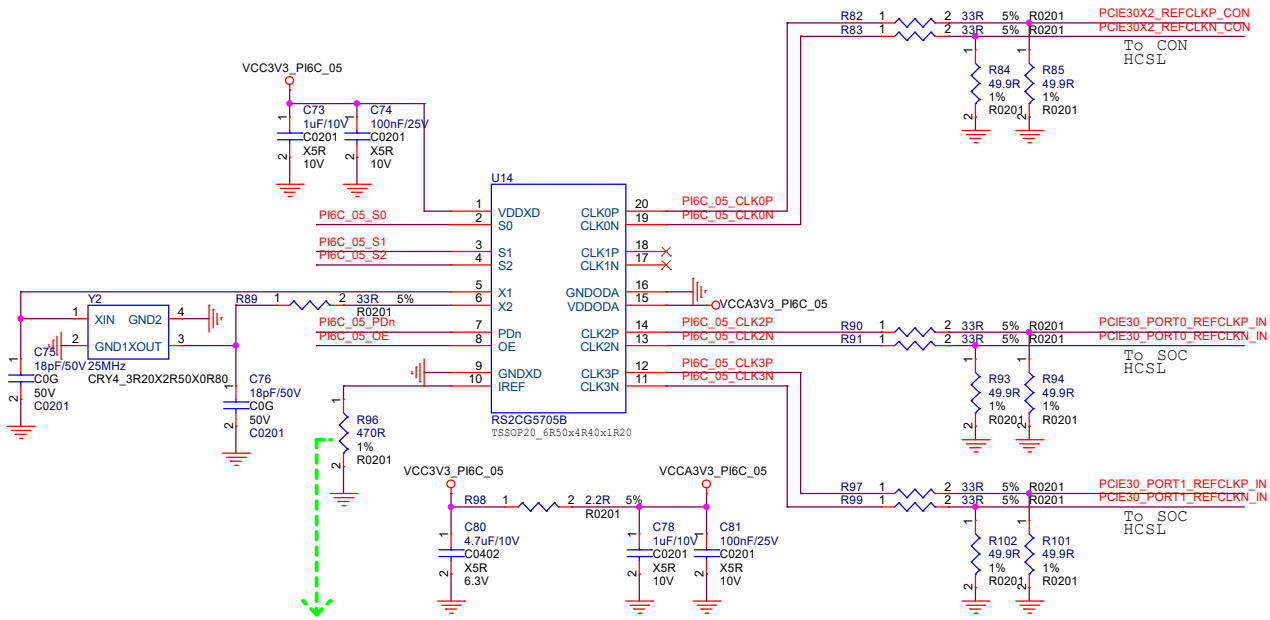
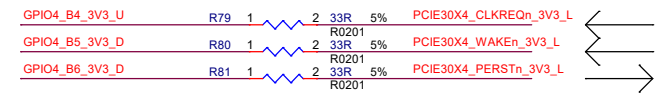
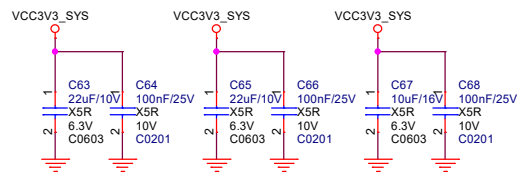
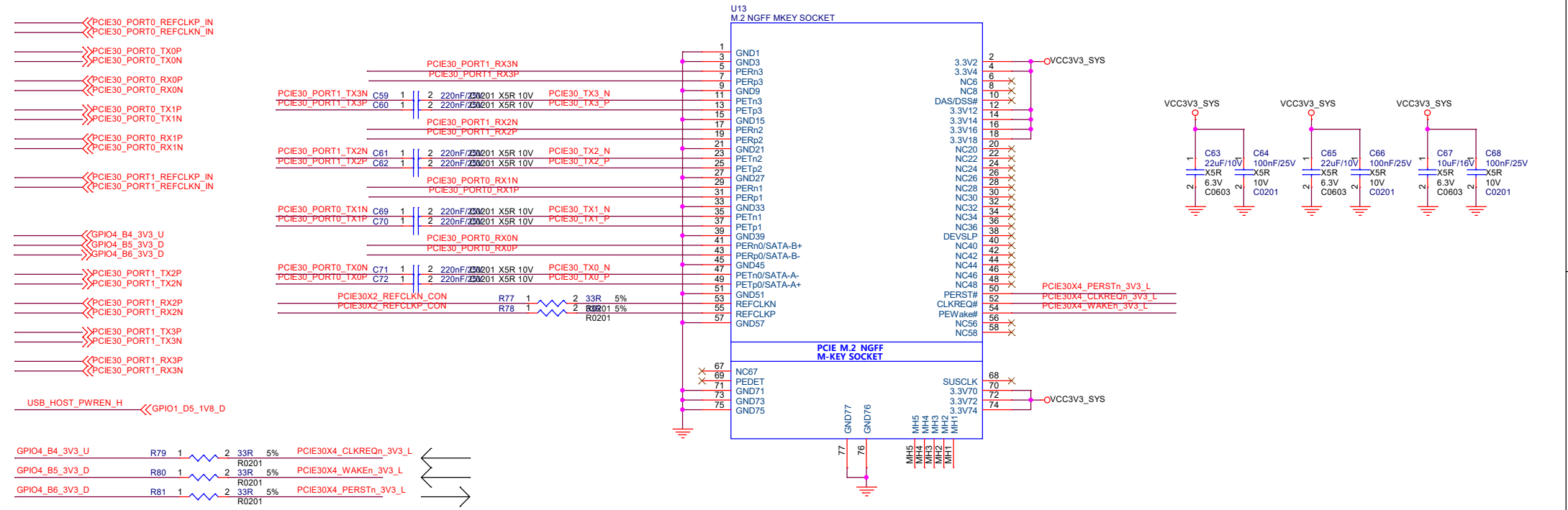

PI6C_S2	PI6C_S1	PI6C_S0	Spread %	Out Freq
0	0	0	-0.5	100MHz
0	0	1	-1.0	100MHz
0	1	0	-1.5	100MHz
0	1	1	No Spread	100MHz

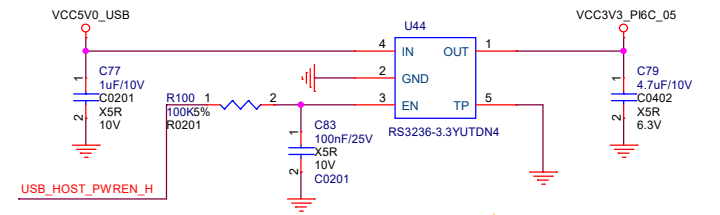
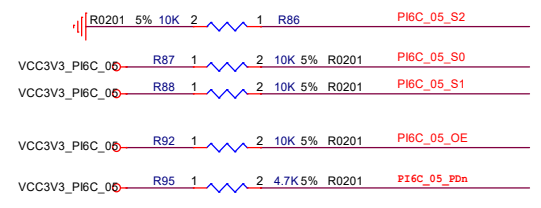

If board target trace impedance is 50ohm then R = 475ohm providing an IREF of 2.32 mA . The output current (IOH) is 6 * IREF . 6x2.32x50=696mV

COOL PI

YANYI www.cool-pi.com

Project: COOLPI-NOTEBOOK	
File: <Page name>	
Date: Wednesday, January 10, 2024	Rev: <Revision>
Designed by: <designer>	Reviewed by: <Checker>
Sheet: 5	of 12

eDP0

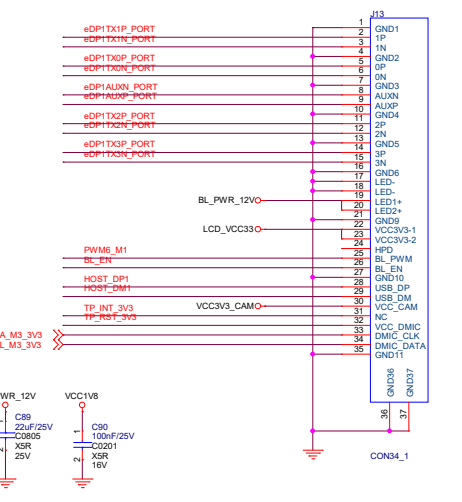
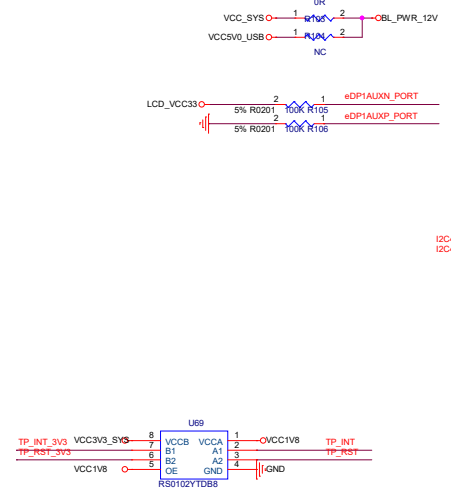
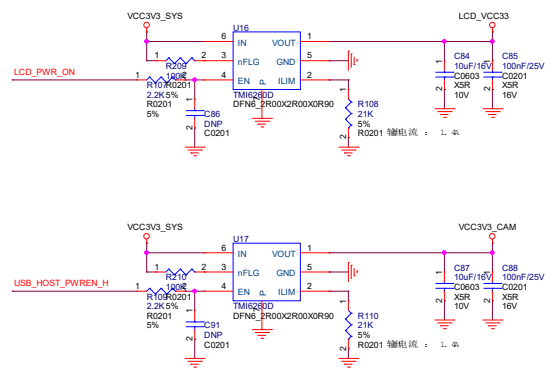
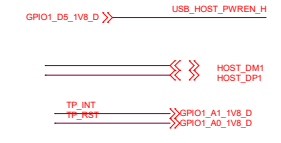
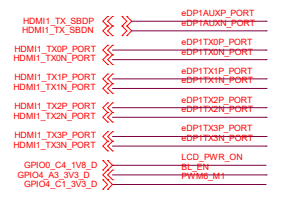

HDMI TX0

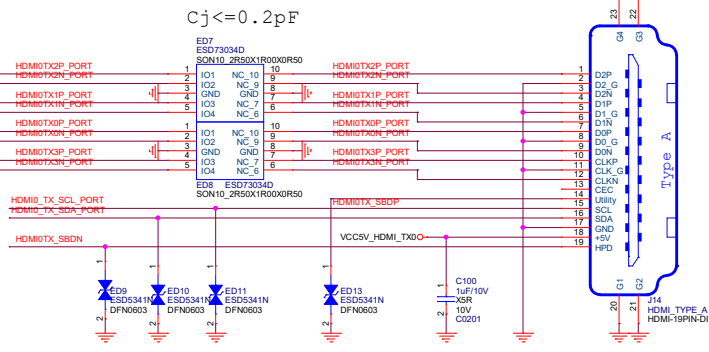
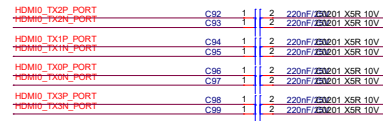
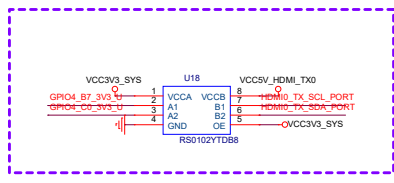
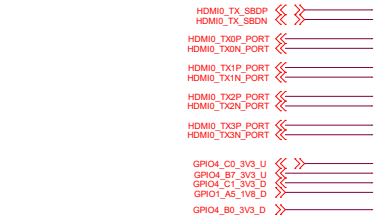

HDMI TX eARC

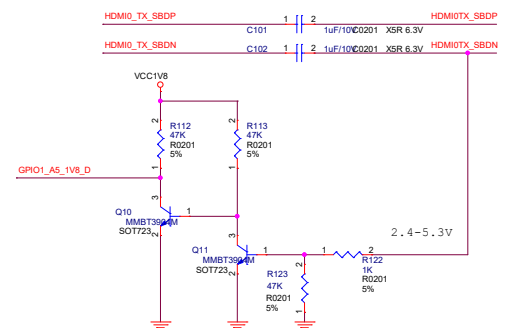

HDMI TX CEC

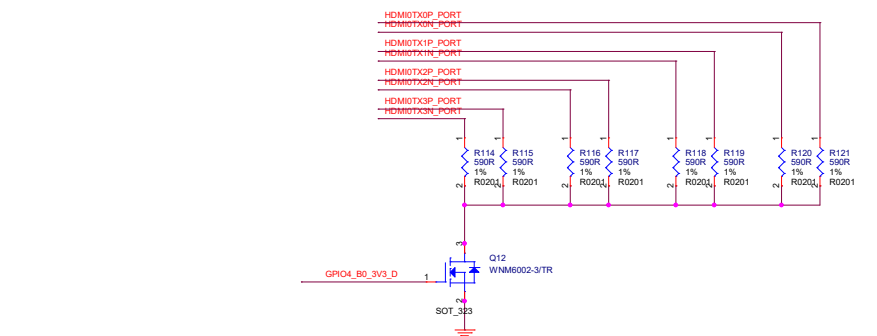

Note:
 HDMI2.0: Stuff R5043, R5044, R5045
 No stuff Q5010, Q5011, Q5012
 HDMI2.1: Stuff Q5010, Q5011, Q5012
 No stuff R5043, R5044, R5045

	5	4	3	2	1
D					
C					
B					
A					
	5	4	3	2	1



YANYI		www.cool-pi.com			
Project:	COOLPI-NOTEBOOK				
File:	<Page name>				
Date:	Wednesday, January 10, 2024			Rev:	<Revision>
Designed by:	<designer>	Reviewed by:	<Checker>	Sheet:	7 of 12

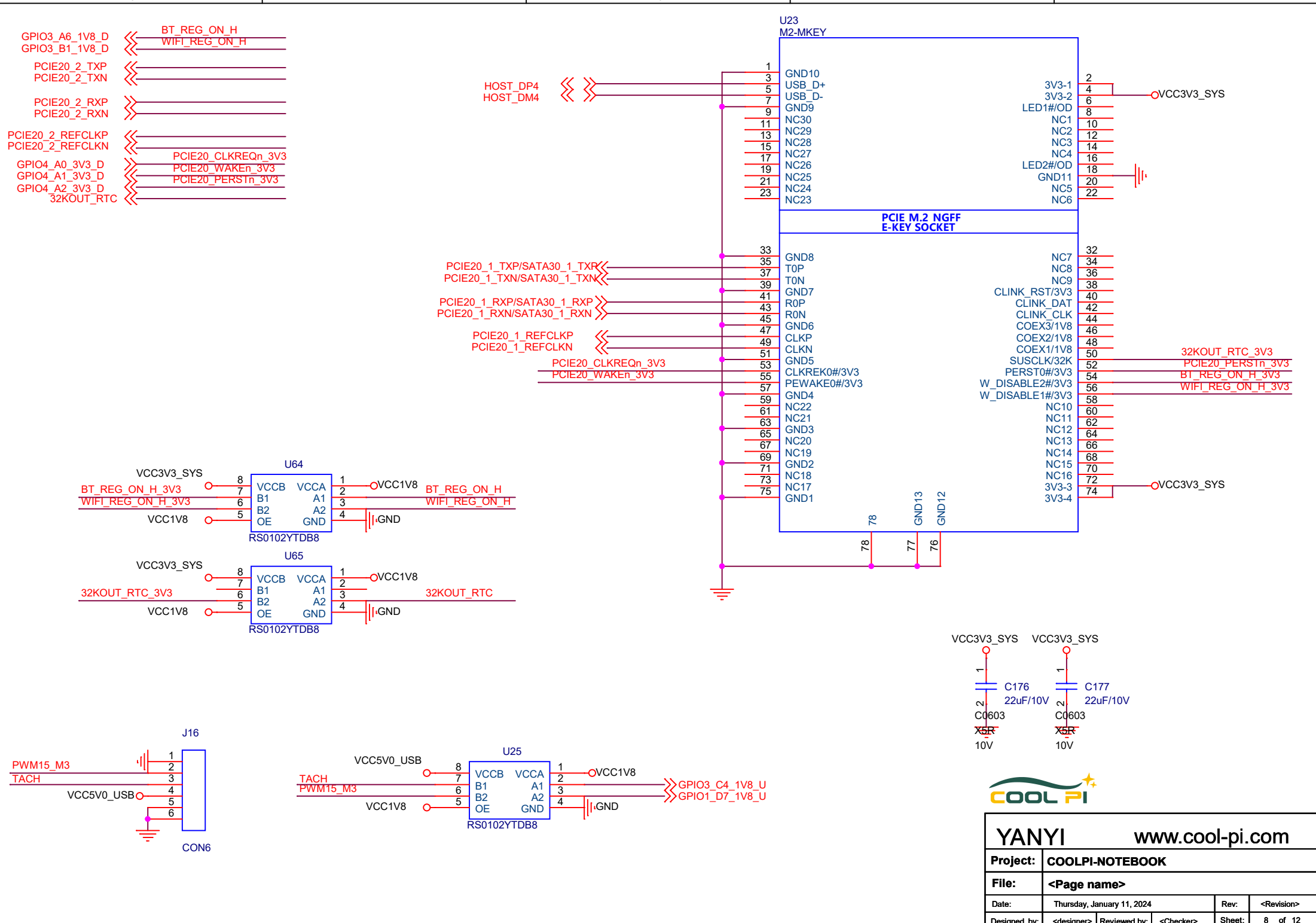

YANYI		www.cool-pi.com	
Project:	COOLPI-NOTEBOOK		
File:	<Page name>		
Date:	Thursday, January 11, 2024	Rev:	<Revision>
Designed by:	<designer>	Reviewed by:	<Checker>
		Sheet:	8 of 12

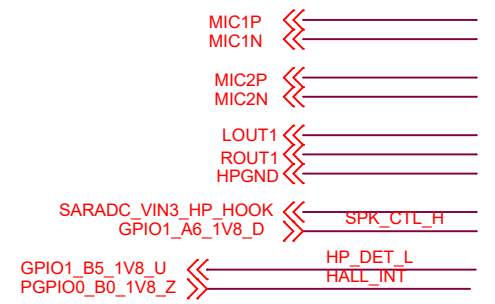
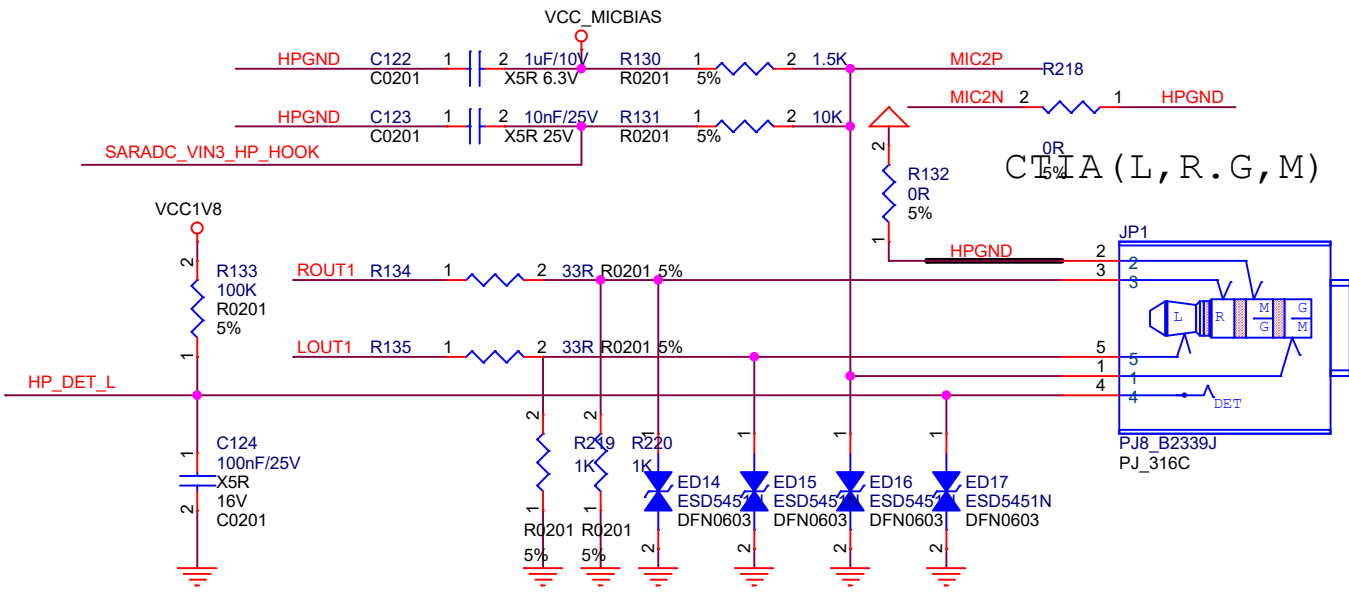

SPEAKER

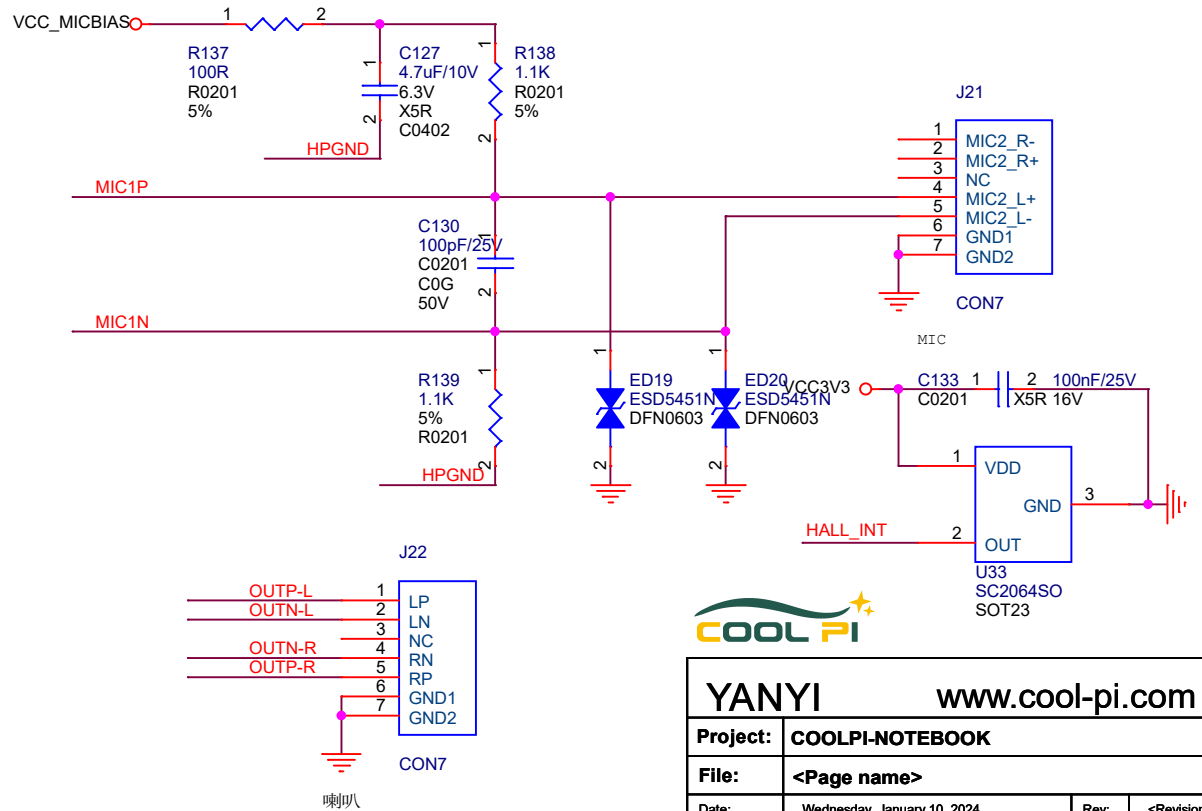
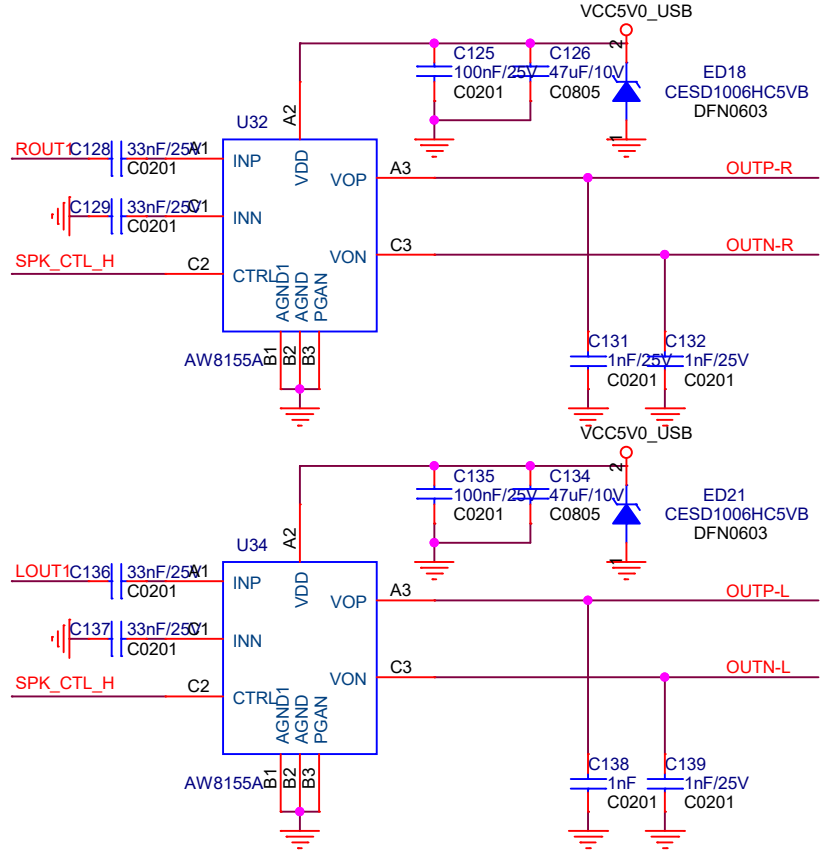

YANYI		www.cool-pi.com	
Project:	COOLPI-NOTEBOOK		
File:	<Page name>		
Date:	Wednesday, January 10, 2024	Rev:	<Revision>
Designed by:	<designer>	Reviewed by:	<Checker>
		Sheet:	10 of 12

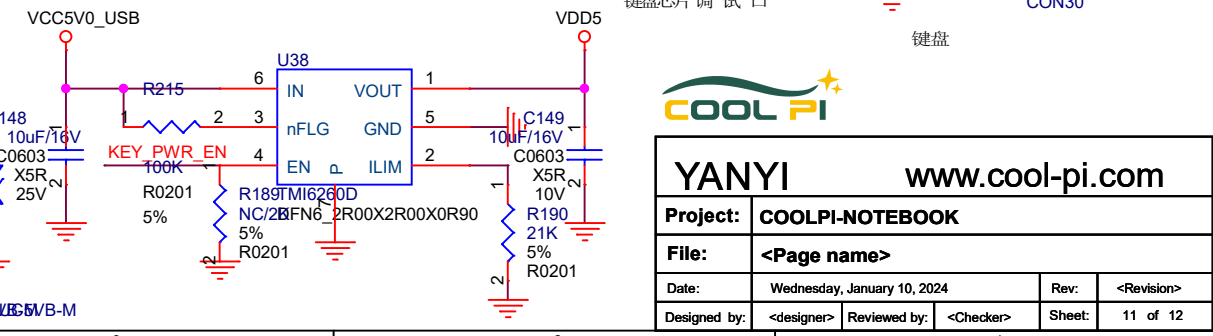
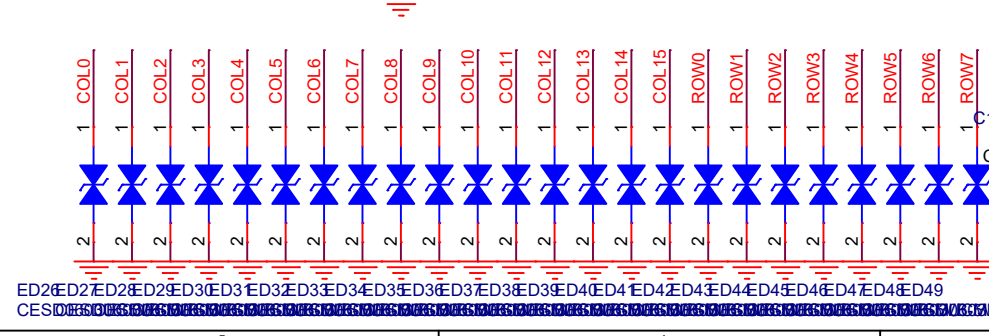
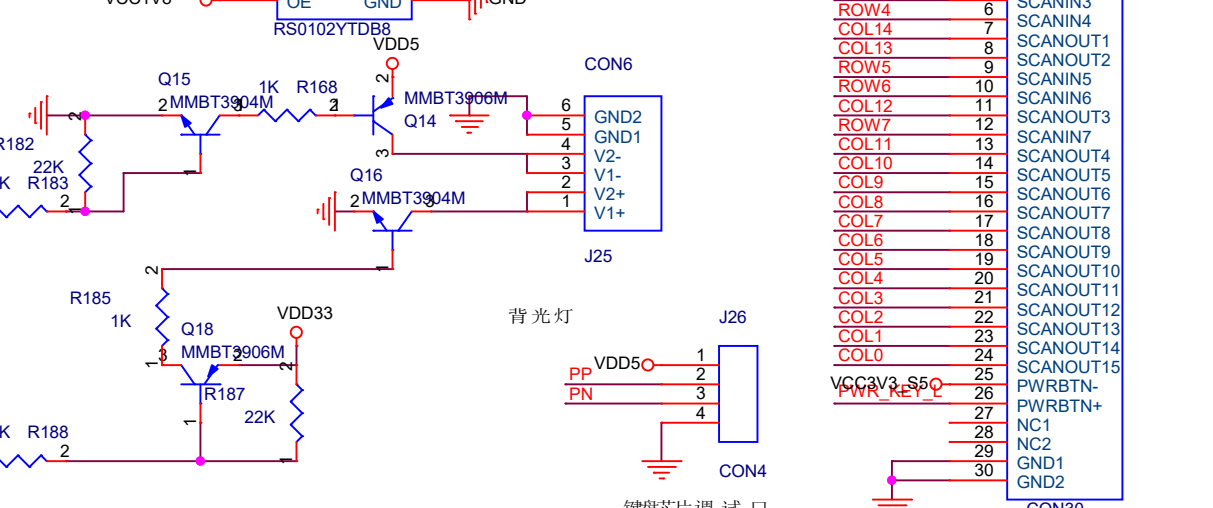
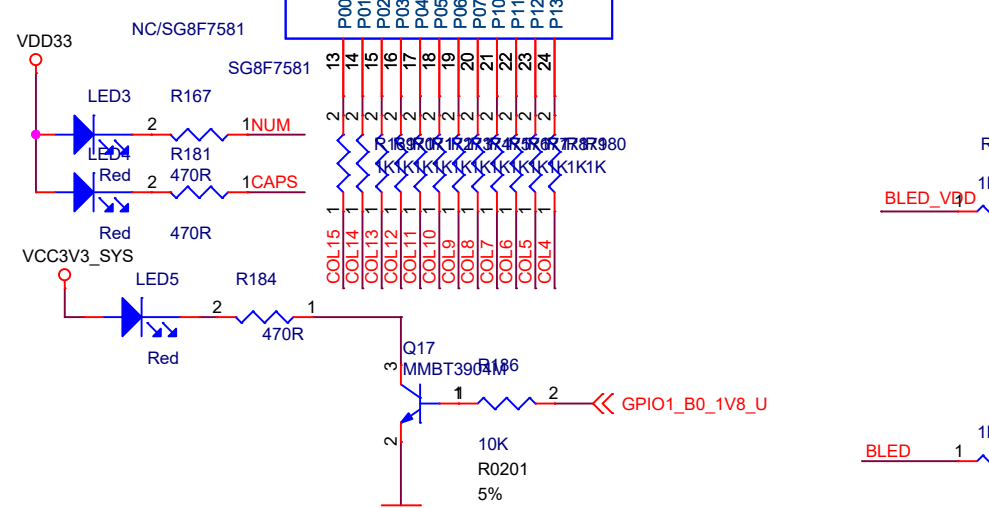
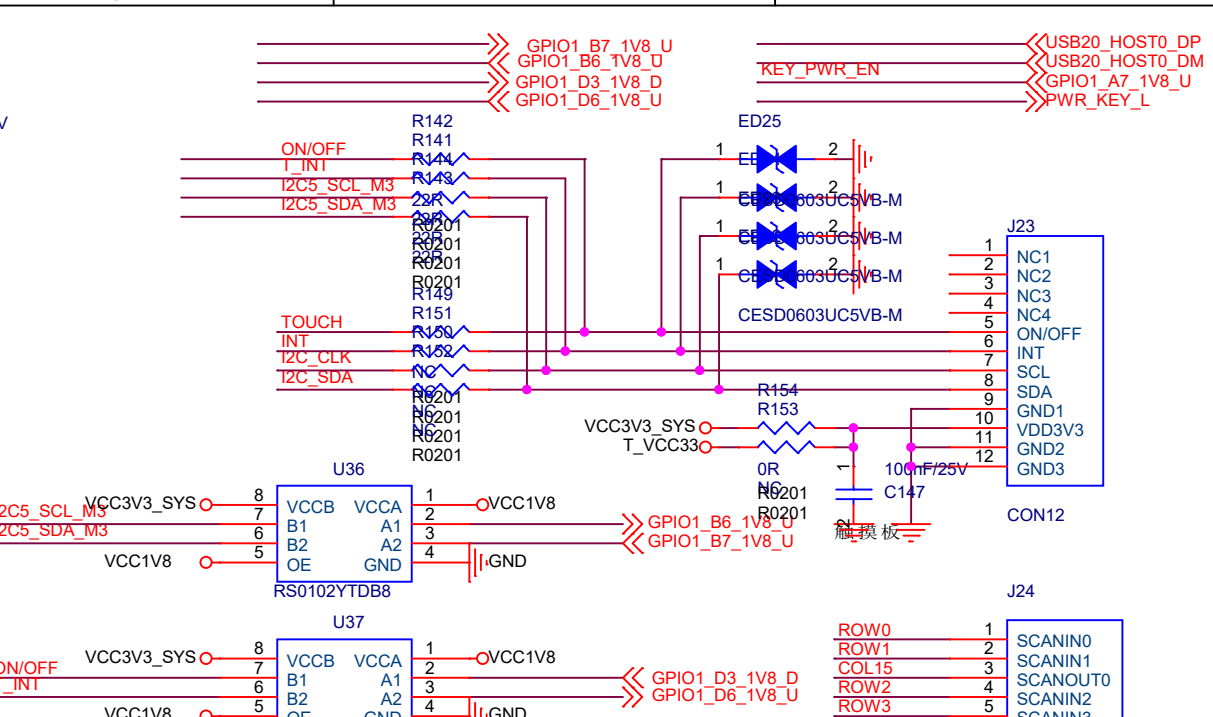
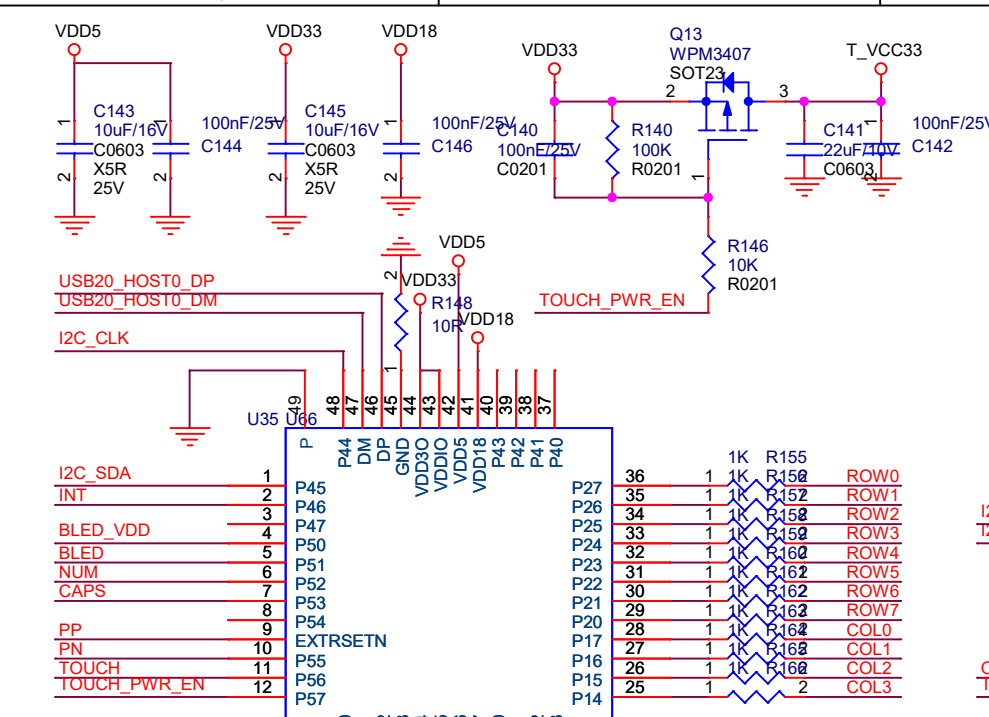

COOL PI

YANYI www.cool-pi.com

Project:	COOLPI-NOTEBOOK		
File:	<Page name>		
Date:	Wednesday, January 10, 2024	Rev:	<Revision>
Designed by:	<designer>	Reviewed by:	<Checker>
		Sheet:	11 of 12

Type-C PORT

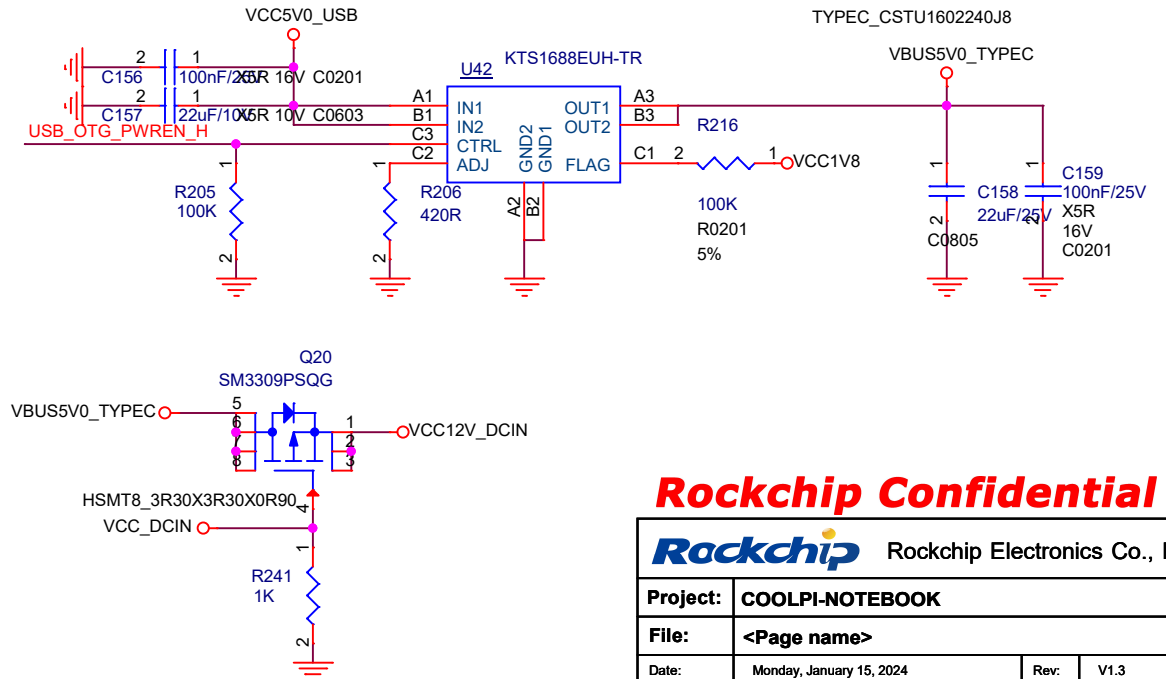
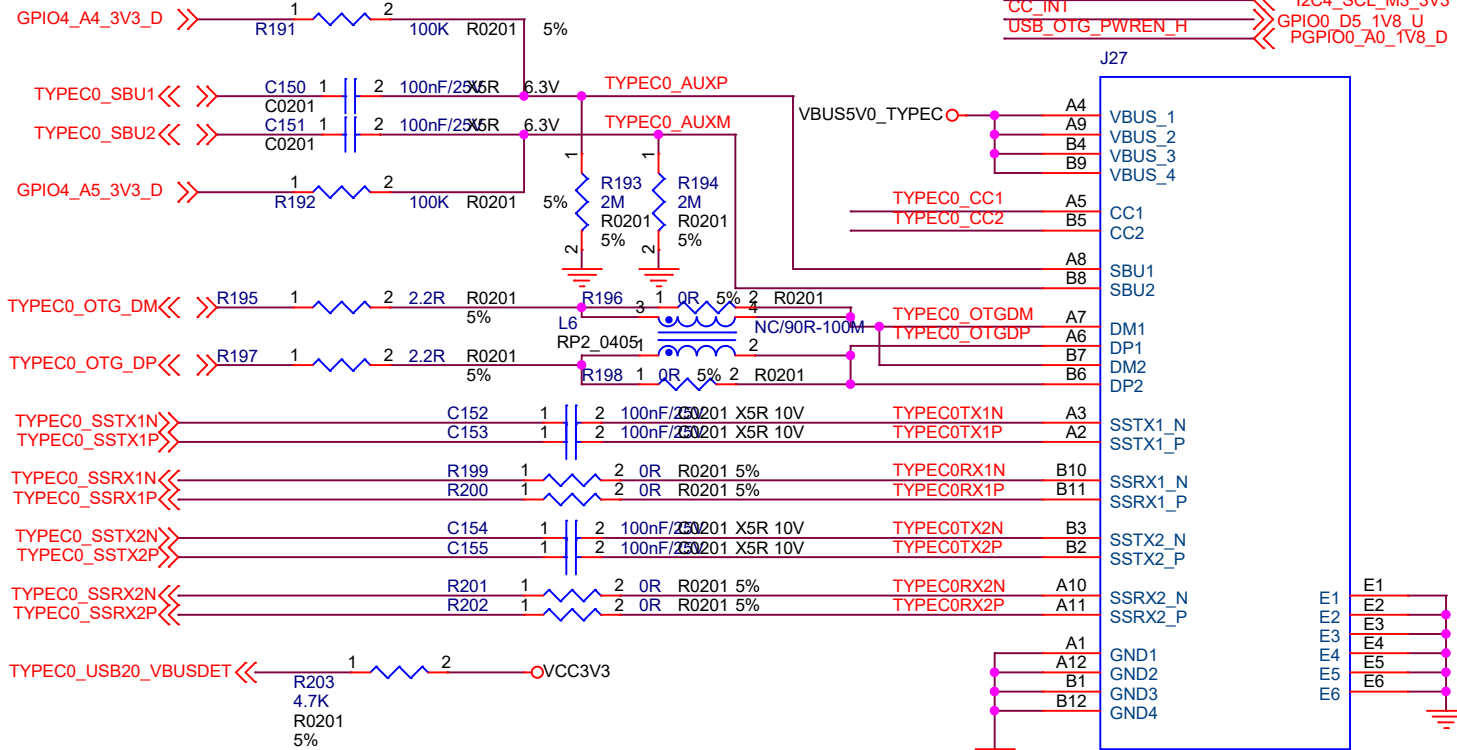
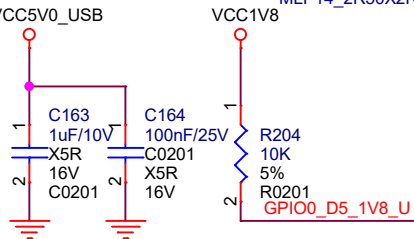
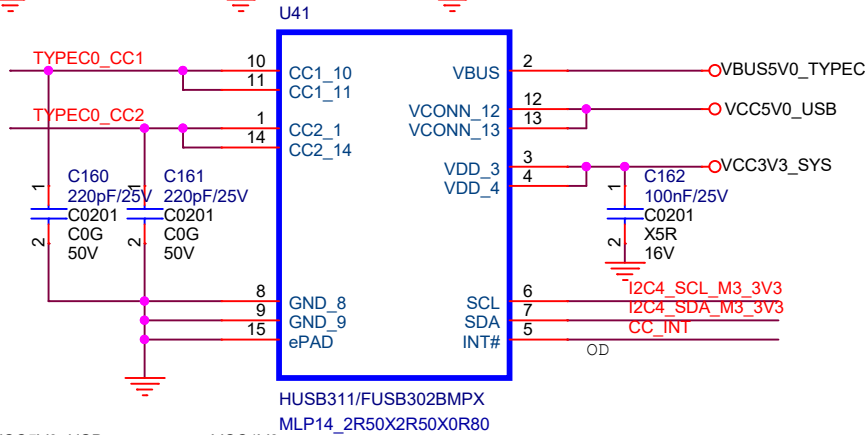
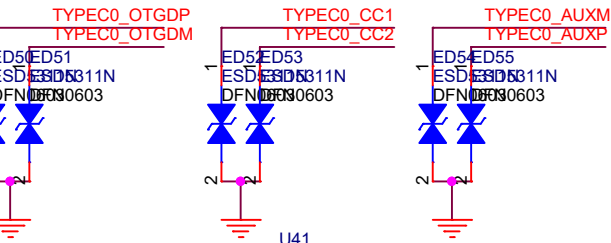
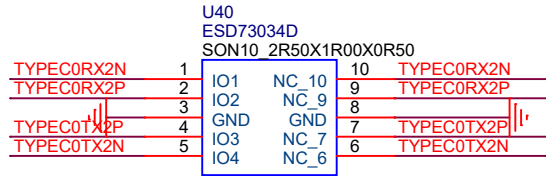
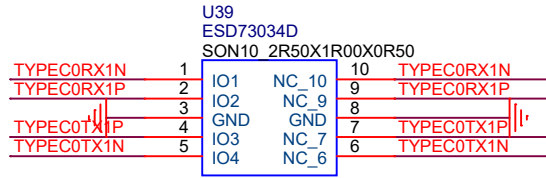

Rockchip Confidential

Rockchip Rockchip Electronics Co., Ltd	
Project:	COOLPI-NOTEBOOK
File:	<Page name>
Date:	Monday, January 15, 2024
Designed by:	RZF
Reviewed by:	
Rev:	V1.3
Sheet:	12 of 12